

# Development of a Generic and Simplified Mathematical Model of a Building Space in MATLAB/Simulink

**Abstract:** MATLAB/Simulink has been widely used for modeling and implementation of advanced control techniques for heating, ventilation and air conditioning (hvac) systems and building spaces. A mathematical thermal model of a building space has been developed in MATLAB/ Simulink. Building space under study is influenced by the hvac systems and occupancy schedules are also incorporated into the model to add practical cases. A simple mathematical equation has been formulated for the building space under study using the energy conservation principle. A first order differential equation depicting the net heat gain in the building space has been modeled in simulink. The building model is fed with climate data (Outdoor temperature profile), hvac plant and internal gains. Ventilation component of hvac system has been modeled using a time schedule technique and a look up table block available in Simulink is used for interpolating number of air changes per hour according to the room's indoor temperature. Internal gain block has been used for time scheduled ventilation. Heater subsystem has a set point block with the desired room temperature and the corrected control signal is then fed to the saturation block to limit the control signal within the specified value. Developed model has been simulated for outdoor temperature climate data and as per the desired set point temperature variations in the indoor room temperature and costs incurred by operating the hvac system has been obtained.

## VSKV Harish

Student Member, IEEE, ASHRAE, CIBSE  
Research Scholar  
Alternate Hydro Energy Centre  
Indian Institute of Technology Roorkee,  
Roorkee, Uttarakhand  
harishvk@gmail.com

## Arun Kumar

Chair Professor (RE) & CSO  
Alternate Hydro Energy Centre  
Indian Institute of Technology Roorkee,  
Roorkee, Uttarakhand

## I. INTRODUCTION

One of the primary obstacles to widespread implementation of optimized controls in the buildings sector is the implementation cost. Each building is unique with specific operational, environmental, occupant, and utility factors that require unique engineered solutions. An integrated approach to building controls should consider interactions between sub-systems and components to guarantee performance over the full range of conditions likely to be encountered. The objective should be to guarantee comfort at minimum operational cost. Adaptive and predictive control strategies would follow from these considerations and be based on real-time modeling and utilization of robust sensor and actuator networks. However, in order to achieve cost-effective implementations, the associated control design and implementation must be automated for deployment in a scalable manner. Building energy simulation tools, such as EnergyPlus or TRNSYS, are appropriate for considering the effect of different supervisory control

variables on energy use and cost. However, they do not integrate necessary tools for investigating MPC and/or determining detailed spatial variations of comfort within individual building zones. Also, they are not generally appropriate for analysis of local-loop feedback control because they do not include dynamics of equipment. A number of methods have been developed to construct load models or energy consumption models that simulate a building / plant system for load prediction or cost saving estimates. Such models vary in magnitude from modeling of a single slab (or a wall) [1] to modeling of a complete building through modeling of rooms subjected to temperature variations.

Clarke [2] gave a three stage process for model formulation. In the first step, the building system is converted from continuous state to a discrete state. This involves selection of nodes at the points under study, representing the homogeneous or non – homogeneous control volumes like that of internal air mass, boundary surfaces, building fabric elements, renewable energy

systems, equipments of the room, etc. Equations satisfying mass, momentum and energy conservation principles are developed in the second step for each node which is in thermodynamic contact with its surrounding nodes. Last step involves solving the equations derived in the second step for successive time steps to obtain state variables of the node for future time periods as a function of present time state variables with the boundary conditions prevailing at both times.

Models developed to simulate the building energy systems can be divided into many types. Basically, models are classified as physical, symbolic and mental models. Symbolic models are comparatively less complex and are thus frequently used. Models can be mathematical and non-mathematical models. Development of mathematical model of a system involves mapping of the physical laws governing the dynamics of the system's process into mathematical relations using variables and constants. Due to ease in evaluation and manipulation mathematical models are the most suitable and the most widely used category of models [3]. Mathematical models can be of theoretical and experimental type. As name suggest, theoretical models involve breaking down of a larger system under study into a number of smaller and simpler subsystems. Mathematical equations constrained through physical laws are then used to relate the different subsystems.

On the other hand, experimental models are developed through empirical relations i.e., through measurement of input and output signals of the system and then, evaluating the system's response. Such models don't provide any information about the mechanics or behavior of the system. Differential or difference equations along with the use of soft computing techniques like fuzzy are made use of in experimental modeling.

Models are also classified as White box, Grey box or Black box models. White box modeling of buildings involve a detailed description of the heat transfer processes occurring in the building. A thorough understanding of the system and all influential sub processes is required to efficiently describe the dynamics of a building energy system [4]. Also called as semi-physical models, Grey box models are inherited from the white box models [5] but the parameters of the model defining the system are not measured directly but estimated through various identification processes [6]. Models which do not normally contain any physical knowledge regarding the system (majorly due to lack of knowledge about the physical structure of the system)

are called as black box models. Statistical methods are used to formulate the model [7] and the physical parameters are partly hidden in the discrete time parameterization. Constructing an accurate and a generic model to interpret the thermal dynamics of a building involves solving heat transfer equations of conduction, convection and radiation and mass transfer equations. Modeling of buildings is not a new concept and has been under research for several years. Numerous models like lumped capacitance models, state space models, frequency domain regression models using conduction transfer functions, thermal response factors have been developed and several works implementing each of the modeling technique has been reviewed. However, to achieve accurate model of a building much more research is required with development of a simple generic model being a mandate [8].

## II. MODEL DEVELOPMENT

### *a. Assumptions*

A mathematical thermal model of a building space has been developed in MATLAB/ Simulink taking into account following assumptions:

1. Construction elements of the building like wall, roof, etc are lumped into a single thermal capacitance.
2. Temperature of the layers of the walls and roof are the same and are equal to the indoor air temperature.
3. Heat loss occurs only due to ventilation (including heat loss due to small air gaps).
4. Air inside the room is well mixed.
5. Heat transfer in the building materials is isotropic.
6. Properties of the material are independent of temperature
7. No internal heat source or sink exists.
8. Heat transfer in the direction across the thickness of each wall or any other slab is considered.

In view of the above mentioned factors, and by energy and mass conservation principle, following equation depicts the net heat gain in the building space.

Net heat = Fabric heat loss + heat loss due to ventilation i.e.,

$$\sum C \frac{dT_{in}(t)}{dt} = U.A. (T_{out} - T_{in}) + \frac{n. (\rho c_p)V}{3600} \Delta T \quad \dots 1$$

where

$$C = \sum_i \rho_i c_{pi} A_i x_i$$

- C: Thermal capacity of the material (JK<sup>-1</sup>)
- ñ: density of the material (kgm<sup>-3</sup>)
- c<sub>p</sub>: specific heat capacity at constant pressure (Jkg<sup>-1</sup>K<sup>-1</sup>)
- A: cross – sectional area (m<sup>2</sup>)
- x: thickness of layer (m)
- i: 1 to no. of layers making up the construction element
- U: Overall heat transfer coefficient (WK<sup>-1</sup>)
- T<sub>out</sub>: Outdoor temperature
- T<sub>in</sub>: Room indoor temperature
- n: No. of air changes per hour (h<sup>-1</sup>)
- V: Volume of room (m<sup>3</sup>)
- T: Temperature difference

On the basis of the above formulated equation a simulink model for the building room space is developed.

*b. Data required running the model*

Density of air at room temperature (273 K) = 1.2041 kgm<sup>-3</sup>

- Heat capacity of air at constant pressure and at 273 K = 1000 (J/kg-K)
- Volume of room = 360 m<sup>3</sup>
- Lumped thermal capacitance of fabric elements = 2064000 J/K
- Set point temperature for the heater = 19 / 20°C
- Overall heat transfer coefficient = 0.3 W/K
- Area = 312 m<sup>2</sup>

**II. MODEL COMPONENTS**

*a. Overall model*

Overall model consists of the building model fed with climate data (Outdoor temperature profile), time scheduled ventilation (a 1-D look up table block; for air changes per hour) and internal gains. Schematic of the block diagram developed in SIMULINK is shown in Fig.1.

The indoor room temperature is then fed to the heater which evaluates the amount of hot air required to blow into the room and the scope plots the results.

*b. Building space model*

Model of the building space is developed by using equation (1). Model uses values of U, A, V and C as constants, takes values of the outdoor temperature, no. of air changes per hour, internal heat gain rates and the heat emitted by the heater as input and computes the room's space indoor temperature. Detailed diagram of the building space model is given in Fig. 2.

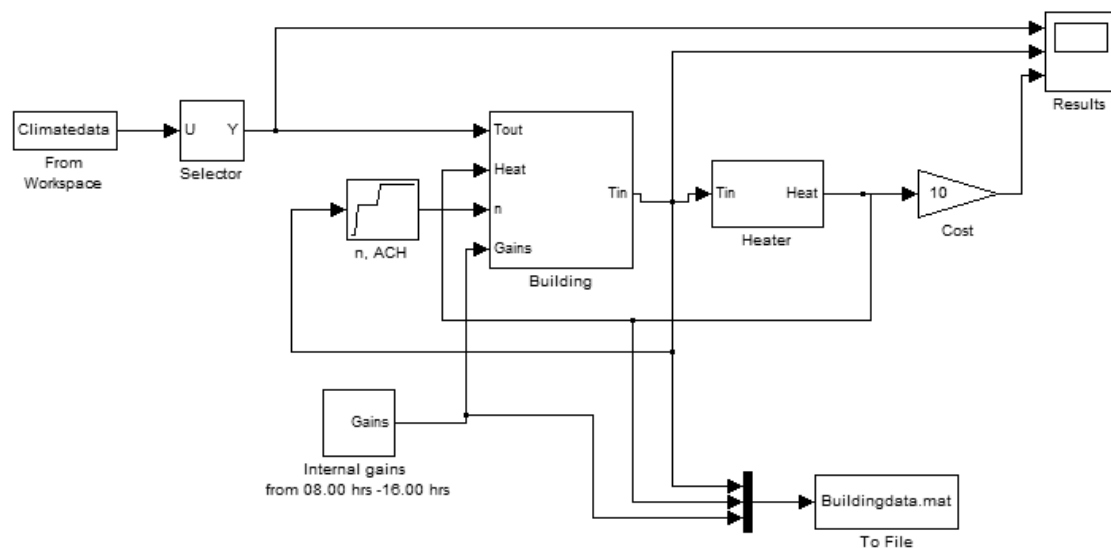

**Fig. 1: Overall Building model in Simulink**

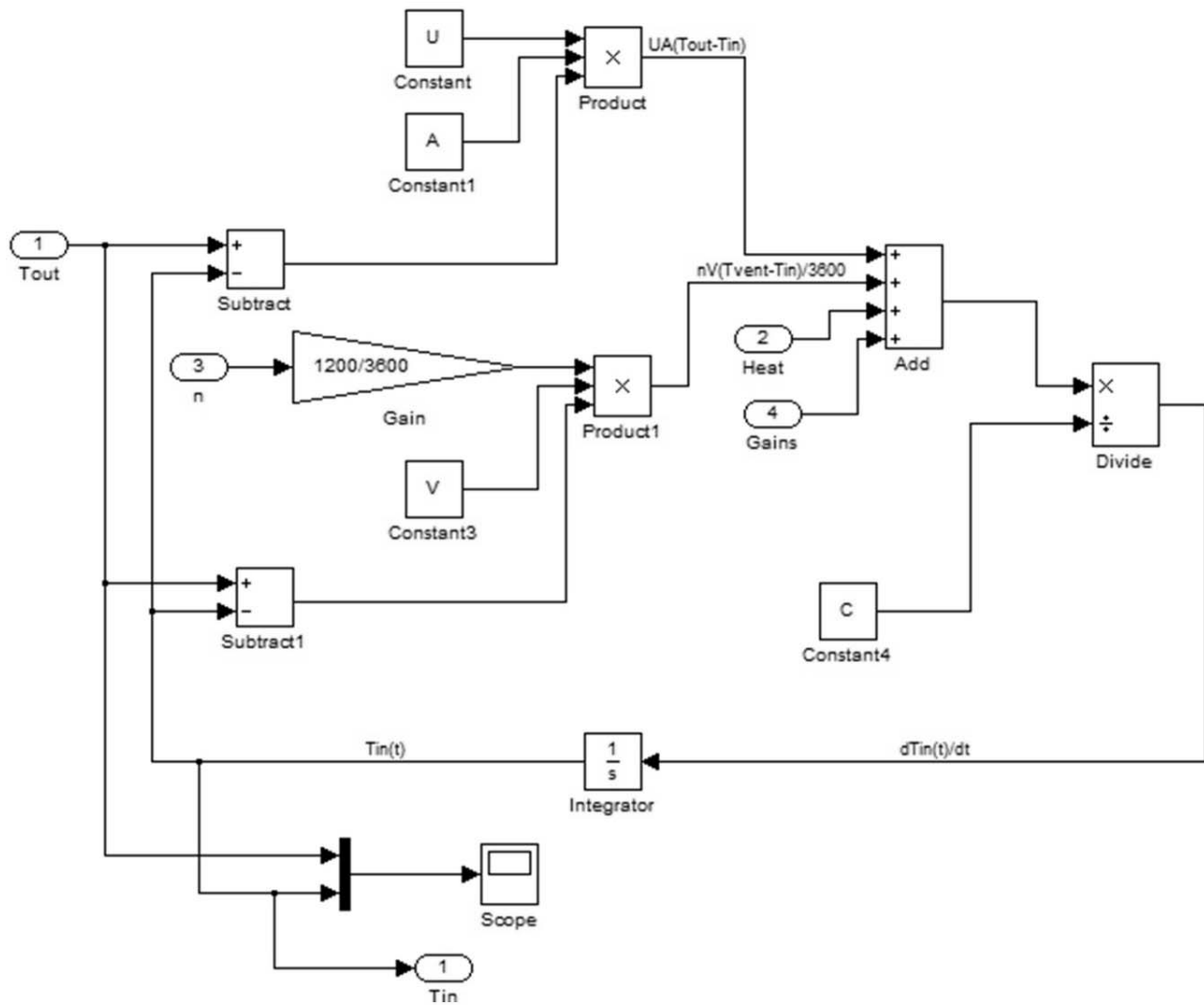

Fig. 2: Building space model

c. Heater Model

The purpose of heater is to maintain the room temperature close to the desired set point temperature. Heater subsystem has been modeled with a set point block with the desired room temperature and the corrected control signal is then fed to the saturation block to limit the control signal within the specified value.

Heater heat rate (W),

$$Q = 0 \forall T_{in} \geq T_{setpoint}$$

$$Q = P (T_{setpoint} - T_{in}) \forall T_{in} < T_{setpoint}$$

d. Internal gains

Internal gain is modeled for time scheduled ventilation, in this case ventilation rate of 2000 W is

provided from 08.00 hrs to 16.00 hrs and 1000W for other hours. A look up table block has been used for interpolating no. of air changes per hour according to the room's indoor temperature, as shown in Fig. 3.

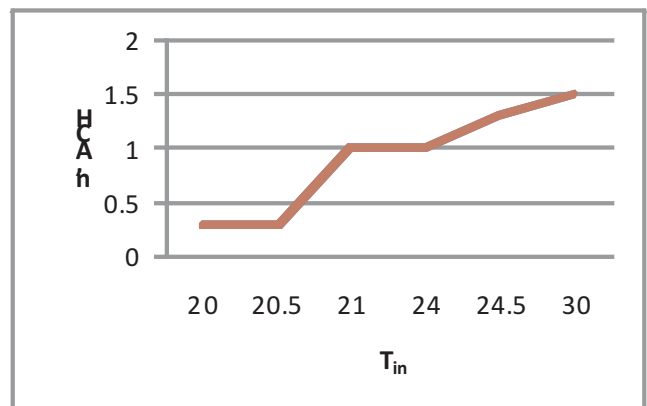

Fig. 3: Number of air changes per hour

#### IV. CONCLUSION

Attaining energy efficiency and energy conservation in buildings requires development of an effective control strategy to automate building energy consumption. Building up of control strategies require and efficient and a precise building model. An integrated approach to building controls should consider interactions between sub-systems and components to guarantee performance over the full range of conditions likely to be encountered. Such an approach has been used to develop a simple thermal model of a building space whose indoor air / environment is regulated through a heater.

#### REFERENCES

- [1]. F. Bruckmayer, "The equivalent brick wall," *Gesundheits-Ingenieur*, vol. 63, pp. 61–65, 1940.
- [2]. J. Clarke, *Energy Simulation in Building Design*, 2nd ed Adam Hilger, Bristol, 1985.
- [3]. I. Škrjanc, B. Zupanèè, B. Furlan, A. Krainer, "Theoretical and experimental FUZZY modelling of building thermal dynamic response," *Building and Environment*, vol. 36, pp. 1023-1038, Nov. 2001.
- [4]. P. Kopecký, "Experimental validation of two simplified thermal zone models," *Proc. 9<sup>th</sup> Nordic Symposium on Building Physics*, Tampere, Finland, 2011.
- [5]. G. Mustafaraj, J. Chen, G. Lowry, "Development of room temperature and relative humidity linear parametric models for an open office using BMS data," *Energy and Buildings*, vol. 42, pp. 348–356, 2010.
- [6]. M. Jimenez, H. Madsen, K. Andersen, "Identification of the main thermal characteristics of building components using Matlab," *Building and Environment*, vol. 43, pp. 170–180, 2008.
- [7]. G. Mustafaraj, G. Lowry, J. Chen, "Prediction of room temperature and relative humidity by autoregressive linear and nonlinear neural network models for an open office". *Energy and Buildings*, vol. 43, pp. 1452–1460, 2011.
- [8]. V.S.K.V. Harish, A. Kumar, "Techniques used to construct an energy model for attaining energy efficiency in buildings", *Proc. 2014 Intl. Conf. on Control, Instrumentation, Energy and Communication*, pp. 421– 425, 2014.

